

STANDARD MOUNTING STYLES AVAILABLE

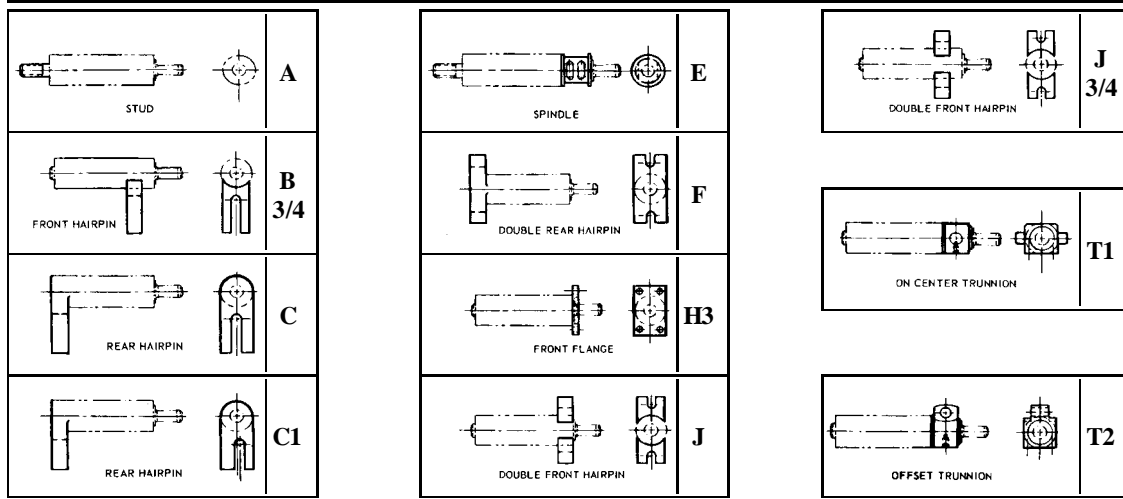

STANDARD ROD END STYLES AVAILABLE

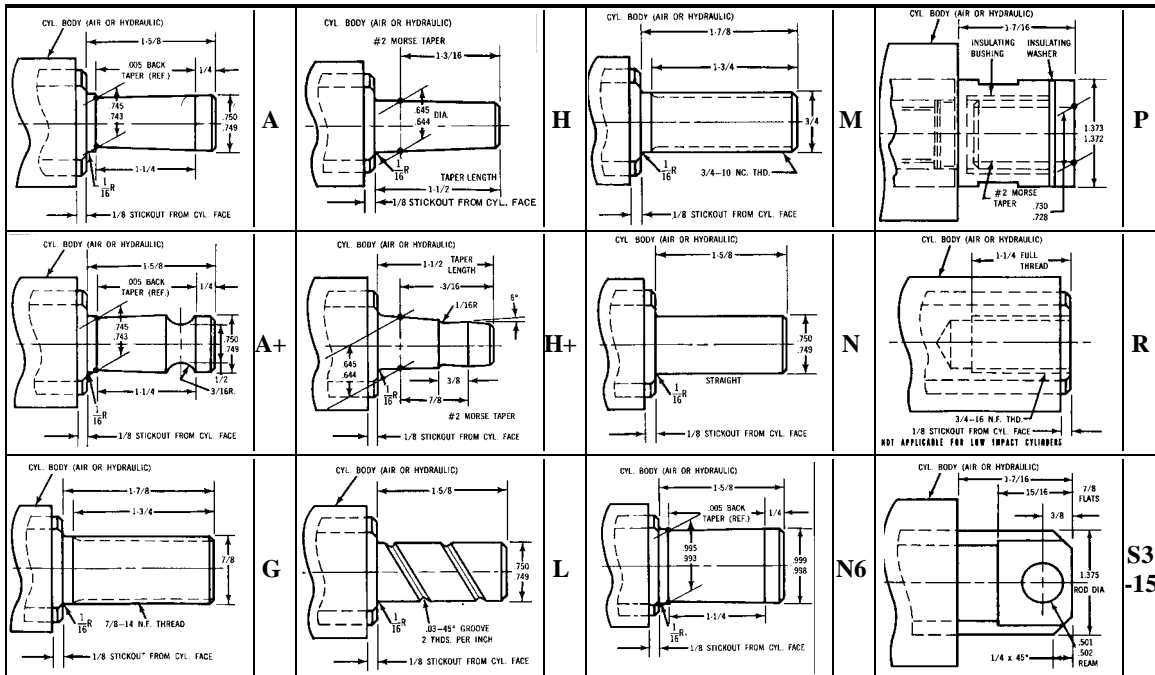

The "N" Rod End Style is the most standard of all listed.

Select mounting style and rod end from above, know your required force and stroke length and contact our office. We will assist you in the selection of the correct SAVAIR Cylinder for your specific application.

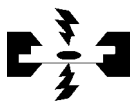

Resistance Welding Equipment & Supply Co.

2045 East 46th Street, Indianapolis, IN 46205

Phone: (317) 251-9406 Fax: (317) 251-9407 E-Mail: rvesco@iquest.net

Visit us on the World Wide Web at: www.spotweldequip.com